

INSTALLATION MANUAL & OPERATION INSTRUCTIONS

BRAKE LATHE * PSE TCBL Installation Manual

PSE TCBL (Brake Lathe) *The Complete Brake Lathe*

LIFT FEATURES:

- Large Chip “Catch” Funnel
- Heavy-Duty Bench
- Micro-Dial Twin Tool Cutter
- High-Impact Anti-Vibration Bands
- Durable Multi-Compartment Toolbox
- Adjustable Lamp
- Safety Shield
- Adjustable Stop Ensures Precision
- Variable Speed Gearbox
- Full Tool Package INCLUDED!
- Other Lathes Available!



Thank You For Your Purchase!

We reserve the right to make changes in specifications without notice and without making changes retroactive.

PRO-SERIES

Equipment

www.ProSeriesEquipment.com

P.O. Box 734
Franklin, Indiana 46131
1-800-708-2988

Email: Sales@ProSeriesEquipment.com

➔ 1.0 Introduction

- 1.1 Read Before Installing
- 1.2 Tools For Installation
- 1.3 Bolt Box Contents
- 1.4 PSE 8,000 CSP Specifications
- 1.5 Major Components

➔ 2.0 Instructions

- 2.1 Installation Instructions
- 2.2 General Safety Instructions
- 2.3 Lift Operating Instructions

➔ 3.0 Maintenance

- 3.1 Maintenance Schedule
- 3.2 Daily Pre-Operation Check
- 3.3 Weekly Maintenance
- 3.4 Yearly Maintenance

➔ 4.0 Trouble Shooting

- 4.1 Trouble Shooting

➔ 5.0 Warranty

- 5.1 Limited Lift Warranty

DISTRIBUTED BY:

PRO SERIES EQUIPMENT
1-800-708-2988
Web: www.ProSeriesEquipment.com
E-mail: Sales@ProSeriesEquipment.com

Packing List of Brake Lathe

No	Description	Qty.	Remarks
1	Main machine	1	
2	Bench	1	Including 20 hooks
3	Twin cutter	1	For processing the Disc
4	Arbor	1	Including nuts and combinative washer
5	Hubless adapter	6	1 pair of each of 094, 0116 and 0146
6	Centering cone	14	025.4
7	Double taped adapter	7	025.4
8	Flange	5	
9	Silencer band	4	1 wide for drum, 1 narrow for drum, 1 wide for disc, 1 narrow for disc
10	Plastic safety shield	1	
11	Spring	3	048x92(1) 046x27(2)
12	Open end wrench	1	27-30
13	Square spanner	1	
14	V-belt	1	A610
15	Boring cutter	6	2 for left Disc, 2 for right Disc and 2 for Drum
16	Sheath	2	051x51
17	Cross feed extension subassembly	1	



DRUM & DISC BRAKE LATHES HANDBOOK



Installation Instructions

Operating Instructions

Safety Instructions

Maintenance Instructions

READ these instructions before placing unit in service. KEEP these and other materials delivered with the unit in a binder near the machine for ease of reference by supervisors and operators.

USER'S RESPONSIBILITY

To maintain machine and user safety, the responsibility of the user is to read and follow these instructions:

1. Follow all installation instructions and make sure installation conforms to all applicable Local, Country's Law, Regulations and Electrical Codes.
2. Carefully check the unit for correct initial function.
3. Read and follow the safety instructions. Keep them readily available for machine operators.
4. Make certain all operators are properly trained, know how to safely and correctly operate the unit, and are properly supervised.
5. Allow unit operation only with all parts in place and operating safely.
6. Carefully inspect the unit on a regular basis and perform all maintenance as required.
7. Service and maintain the unit only with authorized or approved replacement parts.
8. Keep all instructions permanently with the unit and all decals / labels / notices on the unit clean and visible.
9. If ownership of the unit is transferred, provide new user all information in the manual.

SAFETY NOTICES AND DECALS

For your safety, and the safety of others, read and understand all of the safety notices and decals included here and on the unit.



Read entire manual before installing ,
operating, or servicing this equipment.



Proper maintenance and inspection is
necessary for safe operation.



Do not operate a damaged lathe.

⚠ CAUTION ⚠

Prevent accidents and injury, read and follow instructions.



1. Read and follow instructions.
2. Always wear eye protection, avoid loose clothing and jewelry.
3. Keep all guards, shields, and covers in place and in working order.
4. Keep bystanders out of work area.
5. Unplug unit from power source before servicing or adjusting.
6. Maintain unit properly, keep work surfaces and work area clean.

WARNING

This equipment incorporates parts such as snap switches and power receptacles which tend to produce arcs or sparks. Therefore, when located in a service facility, the unit should be in a room or enclosure provided for the purpose, or should be at least 18 ' or more above floor to minimize the risk of igniting fuel vapors.

CAUTIONS AND DANGERS

1. Eye and face protection requirements:

“Protective eye and face equipment is required to be used.

Protective goggles, safety glasses, or a face shield must be provided by the purchaser / user and worn by the operator of the equipment. Make sure all eye and face safety precautions are followed by the operator(s). Keep bystanders out of the area.

2. Do not remove any safety equipment, belt guards, or shortcut controls or operations.

3. Make sure drums and rotors are properly and squarely mounted before starting lathe and that all parts are secure.

4. Do not wear loose clothing, jewelry, or gloves when operating or working around a lathe.

5. Do not overload the lathe. Read and understand the lathe specifications. Overloading is poor machine tool practice, shortens the life of the lathe, and could cause a failure resulting in personal injury.

WARNING

Failure to follow danger, warning, and caution instructions may lead to serious personal injury or death to operator or bystander or damage to property. Do not operate this machine until you read and understand all the dangers, warnings and cautions in this manual.

IMPORTANT SAFETY INSTRUCTIONS

Before operating the lathe, review the warning information on the lathe and the cautions, warnings and dangers in this manual. Also review the following general safety instructions. Failure to follow safety instructions could result in personal injury to operator or bystanders and damage to the lathe or personal property.

READ ALL INSTRUCTIONS

1. Keep guards in place.
2. Remove adjusting keys and wrenches from the tool before turning it on. Make this a habit.
3. Keep work area clean. Cluttered areas and benches invite accidents.
4. Avoid dangerous operating environments. Do not use equipment in areas where explosive vapors are present or in damp or wet locations. Do not expose them to rain. Keep the work area clean and well lighted.
5. Keep children away. All bystanders should be kept completely away from the work area.
6. Make the workshop kid-proof. Use padlocks and master switches; and remove starter keys.
7. Don't force a tool. It will do the job better and safer at the rate for which it was designed.
8. Use the right tool. Don't force a tool or an attachment to do a job for which it was not designed.
9. Dress properly. Keep loose clothing, gloves, neckties, shop rags or jewelry away from moving parts. Non-slip footwear is recommended. Wear protective hair covering to contain long hair.
10. Wear eye protection. Safety glasses, goggles, or a face shield will help protect the operator from injury. Use a face shield and dust mask during dusty operations.
11. Secure the work properly to the unit for setup and tool bit positioning. Do not attempt to hold a drum or rotor steady on the arbor with your hands. Both hands must be free to operate unit.
12. Keep distance at all times when lathe is in operation.
13. Maintain tools with care. Keep tools sharp and clean for best and safest performance. Follow instructions for lubricating and changing accessories.
14. Remove power from the unit and disconnect tools before servicing and when changing accessories. Follow lock-out and tag-out procedures as required.
15. Avoid unintentional starting. Make sure the switch is in the OFF (0) position before plugging the machine in or performing any maintenance or service work.
16. Use recommended accessories. Consult the manufacturer's catalogs for recommended accessories. Use of improper accessories may cause risk of injury to operator or bystanders.
17. Never stand or lean on a lathe. Serious injury could occur if the lathe is tipped or if the cutting tool is unintentionally contacted.

Continued Next Page

READ ALL INSTRUCTIONS (continued)

18. Check damaged parts carefully. Before further use of the lathe, a guard or other part that is damaged should be carefully checked. Immediately replace all damaged, missing, or non-functional parts. Check for alignment of moving • binding of movinn parts. breakage o parts, moi'ntinri and any other conditions that may attect operation. Guards and other parts that are damaged should be properly repaired or replaced before lathe is used again.
19. Always feed the work into a blade or cutter and against the direction of rotation. Cutters and tool bits are designed to cut from the inside of a drum or rotor to the outer edge. Do not attempt to cut from the outside edge in to the centet.
20. Never leave tools running unattended. Turn the power off. Don't leave the tool until it comes to a complete stop.
21. Never use compressed air to blow the tool clean. Chips and dust may be driven between machined parts arid into bearing, causing undue wear. They may also contact persons in the area causing personal injury.
22. Operate the lathe in the proper environment. The lathe incorporates parts such as snap switches and power receptacles which tend to produce arcs or sparks. Therefore ,when located in a garage, the unit should be in a room or enclosure provided for the purpose , or should be at least 18 "or more above the floor to minimize the risk of igniting fuel vapors.

BEFORE YOU BEGIN

Receiving

The shipment should be thoroughly inspected as soon as it is received. The signed bill of lading is acknowledgement by the carrier of receipt in good condition of shipment covered by our invoice.

If any of the goods called for on this bill of lading are shorted or damaged, do not accept them until the carrier makes a notation on the freight bill of the shorted or damaged goods. Do this for your own protection.

Notify the carrier at once if any hidden loss or damage is discovered after receipt and request the carrier to make an inspection. If the carrier will not do so, prepare a signed statement to the effect that you have notified the carrier (on a specific date) and that the carrier has failed to comply with your request.

It is difficult to collect for loss or damage after you have given the carrier a clear receipt.

File your claim with the carrier promptly. Support your claim with copies of the bill of lading, freight bill, invoice, and photographs, if available.

Although our responsibility ceases upon shipment to the carrier, we will gladly assist in tracing lost shipments. Our willingness to assist in every possible manner does not make us responsible for collection of claims or replacement of lost or damaged materials. Shipping damage claims will not be handled under warranty.

Electrical Requirements

The lathe must be properly grounded to protect the operator from shock. The lathe is equipped with an approved 3-conductor cord and a 3-prong grounding type plug to fit the proper grounding-type receptacle. Should an extension cord be required, use 3-conductor cords with 3-prong grounding plug and 3-prong grounding receptacle properly rated to handle this electrical power tool only. Do not modify a cord or plug to match a receptacle; have a qualified electrician install an appropriate outlet to match the lathe requirements. Repair or replace any worn or damaged power cords immediately.

Verify that the lathe plug and grounding-type receptacle match as shown in Figure 1.

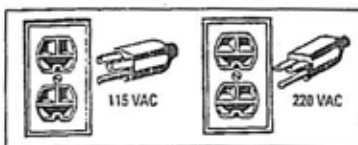

Figure 1 -Power Cord Plug and Receptacle Types

INSTALLATION

1. Assemble bench according to the instructions provided. Tighten all fasteners securely.
2. After assembly, the bench should be leveled and may be bolted down with bolts or Screws.
3. Unbolt the lathe from the shipping pallet. Lift the lathe onto the bench,
4. Bolt the lathe to the bench with the hardware provided. Tighten fasteners securely.
5. Remove any packing materials and protective wrapping from the lathe and components.
6. Make sure lathe is turned off. Plug lathe into a properly installed and grounded outlet that matches the lathe plug.
7. Remove the shipping plug, insert the oil dipstick, and check oil level. The lathe is shipped with the correct amount and type of oil. Add oil as necessary to reach the correct mark on the dipstick. Use only MOBIL EP-80-90 lubricating oil. Oil level should be checked often.

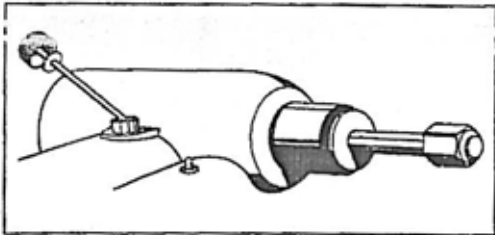

Figure 2- Check oil level

8. Clear the area and turn lathe on. Check for proper operation (motor and spindle rotation).

Preparation for Use

1. Inspect all adapters and accessories for burrs, nicks, or other damage.
2. Clean accessories with a vaporizing solvents.
3. Apply a light film of oil to all adapters to protect their machined surfaces from rust. Refer to the maintenance section for more information.

WARNING

There is a circuit breaker located on the electrical panel to prevent damage to the lathe in the event the motor is overloaded. Move the switch to the off position and correct overloading situation before re-setting circuit breaker. Serious personal injury could result if circuit breaker is re-set while lathe is still on.

OPERATING SPECIFICATIONS

1	17.25" (438 mm)
2	410 lbs(186 kg)
3	48" (1219.20 mm)
4	34.5" (901.70 mm)
5	39.375" (1000 mm)
6	Standard: 115 VAC, 60 Hz, single-phase, 12A
7	Optional: 220 VAC, 60 Hz, single-phase, 5.21A
Motor	1 HP, 60 Hz, 115/230 VAC
Spindle travel	9.875" (251 mm)
Spindle speed	
Inner Groove	70 RPM
Middle Groove	88 RPM
Outer Groove	118 RPM
Spindle feed speed	Infinitely variable
Minimum	0.002 inch/rev (0.05 mm/rev)
Maximum	0.020 inch/rev (0.50 mm/rev)
Cross travel	3.94 inch (100mm)
Cross feed speed	
Fine	0.002 inch/rev (0.05 mm/rev)
Course	0.010 inch/rev (0.25 mm/rev)
Maximum brake rotor diameter	14.5" (368.3 mm) Cross Feed Extension lathes increases the maximum rotor diameter to 19" (483 mm)
Maximum brake rotor thickness	4" (102 mm)
Brake drum diameter	
Minimum	6" (152 mm)
Maximum	28" (711 mm)
Maximum drum depth	9.875" (251 mm)
Maximum load	
1" Arbor	100 lbs. (45.36 kg)
1.875" Arbor	200 lbs. (90.72 kg)

INSTALLATION

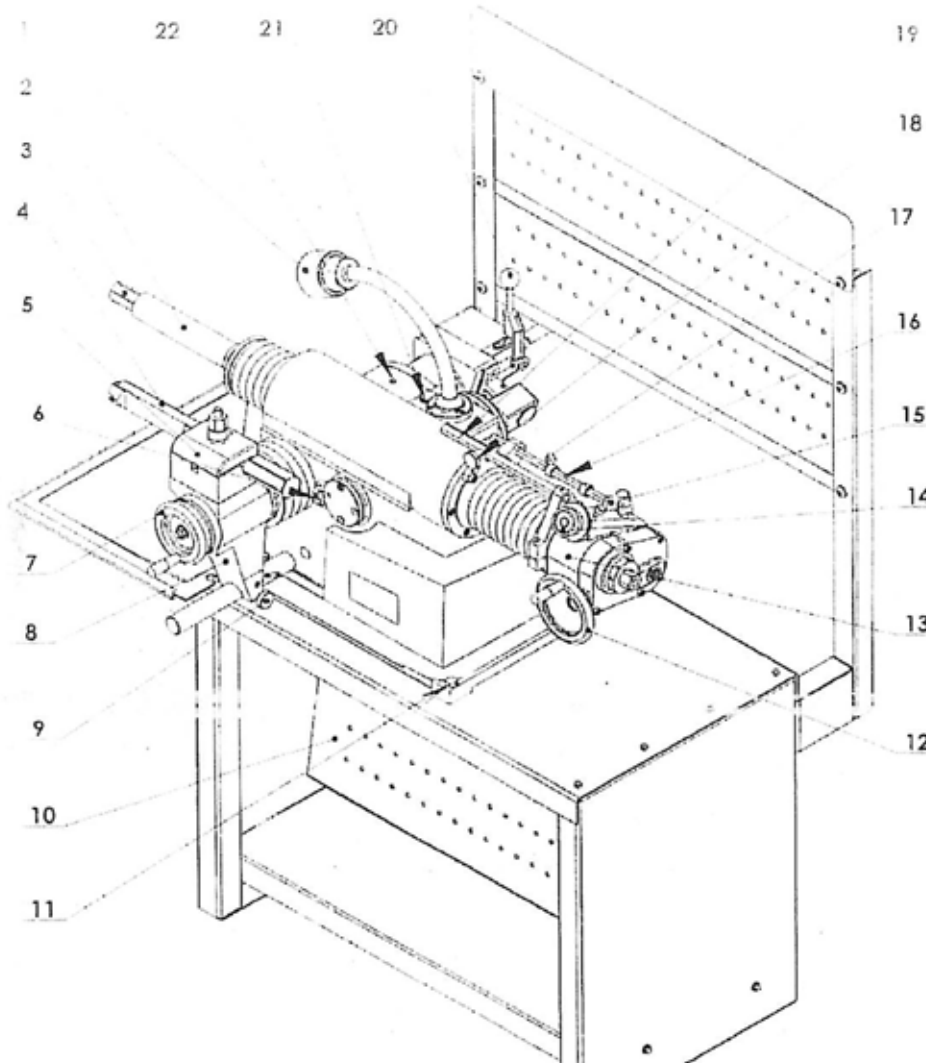

1-Work Light 2-Spindle 3-Spindle Nut 4-Boring Bar 5-Boring Bar Clamp 6-Oil Plug 7-Cross Feed Handwheel 8-Cross frame 9-Cross Feed Lock 10-Bottom Plate 11-Bolt 12-Spindle Feed Handwheel 13-Spindle Feed Gearbox 14-Spindle Feed Dial 15-Spindle Feed Clutch Lever 16-Spindle Travel Control Rod 17-Control Rod Lock 18-Spindle Lock 19-Spindle Rod 20-Cross Feed Adjusting Lever 21-Oil Dipstick 22-Grease Fitting

Arbor Installation

The 1 "arbor shipped with the lathe has been carefully matched to the lathe during final assembly and testing. Witness marks have been etched onto the arbor and the spindle for precise, repeatable alignment.

The witness marks must be carefully aligned when installing the arbor (Figure 3)

INSTALLATION

1. Locate the witness marks on the arbor and the spindle.

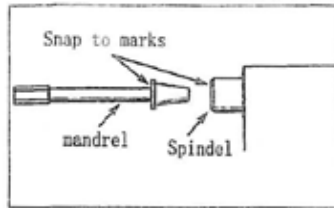

Figure 3-Align witness marks during arbor installation

2. Insert the arbor into the spindle making sure the witness marks are aligned.
3. Tighten the draw bar (located at the rear of the spindle) to pull the hardened and ground tapers of the arbor into the matching seats in the spindle.

Change and Choose Arbor:

New arbor must be marked because of no sign.

1. Spindle hole and arbor tapers must be clear.
2. Fix arbor and lock the draw bar.
3. Measure arbor radial flop with centesimal meter.
4. If radial flop < 0.001 inch, mark a sign on arbor near spindle.
5. If radial flop > 0.001 inch, loose draw bar, round $1/8$ arbor and lock draw bar.
6. Check radial flop once more.
7. If radial flop > 0.001 inch, do 5 and 6 until radial flop < 0.001 inch, then mark a sign.

Adapters:

Important: Although the adapters, arbor, and spindle are made of top grade steel and are turned, hardened, and precision ground to close tolerances, great care should be taken in their use, handling, and storage. Even the smallest nick, scratch, or loose chip on the Machined mating surfaces can cause incorrect rotor mounting alignment. This will cause inaccurate machining.

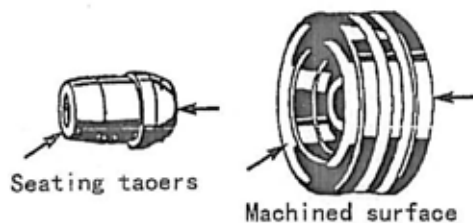

Figure 4-Use care to avoid damaging mating surfaces

Always inspect the surface, face, and seating tapers of each part before use. Wipe each part clean before and after using it. Carefully correct any flaw with a fine stone. If damage cannot be corrected, replace the part.

Basic Operation

To completely understand drum and rotor turning you must have a knowledge of the lathe itself.

INSTALLATION

Spindle

The spindle is a motor driven shaft that turns the arbor upon which the brake drum or rotor is mounted. By turning the drum and holding a cutting tool against the inner braking surface, metal can be removed. Do not try to move any feed levers or dials without the drive motor running. Damage may occur to the gear trains.

Spindle Feed

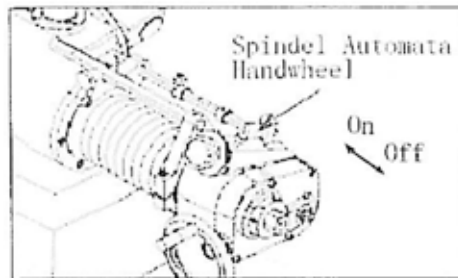

Figure 5-Sindle Feed Clutch

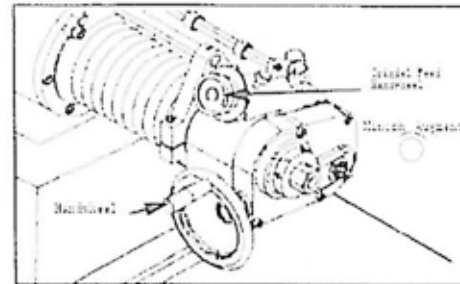

Figure 5-Sindle Feed Clutch

By operating the spindle feed lever, the spindle will move the mounted brake drum to the left. This feeds the braking surface across the cutting tool as the drum moves away from the tool. Spindle feed may also be done manually using the spindle feed hand wheel.

Spindle feed refers to the distance the spindle is pulled per revolution. This speed is adjustable.

Important. Spindle feed must be adjusted with lathe running otherwise be mangled.

Rotate the spindle feed dial to the desired feed rate. The rate is adjustable to any point between 0.002k (0.05 mm) and 0.020" (0.50 mm).

Spindle Speed

Spindle speed is measured in RPMs and is adjustable. Refer to the specifications listed on page 11 for the RPM rating of each groove on the V-belt pulley for each model.

Spindle Speed Adjustment

This V-belt adjustment must be made with the lathe off.

1. Release the belt tension by moving the V-belt adjusting lever to the right (clockwise).
2. Move the belt to the pulley groove that will give the correct spindle speed for the cut to be taken.
3. Reapply tension to the V-belt by moving the adjusting lever back to the operating position.

Cross Feed

The cross feed draws the tool bit across the face of a brake rotor or flywheel when the cross feed drive is engaged. The cross feed may also be operated manually using the cross feed hand wheel.

Feed speed refers to the thousandths of an inch the cutting tools move per revolution of the spindle.

The cross feed speed is adjustable.

Using the 3-position lever, select Fine (0.002" [0.05 mm]) or Coarse (0.010").

INSTALLATION

([0.25 mm]). The Neutral position is the off position (no movement). The cross feed may also be operated manually.

V-Belt Tension and Adjustment

A loose belt can cause slippage when taking heavy cuts. A belt that is too tight can cause vibration and possible sub-standard finishes on machined drums and rotors. Check and adjust belt on a monthly basis.

There should be between $\frac{1}{4}$ to $\frac{1}{2}$ of play in the belt.

1. Loosen the adjustment nut.
2. Position the v-belt speed adjusting lever to the right position.

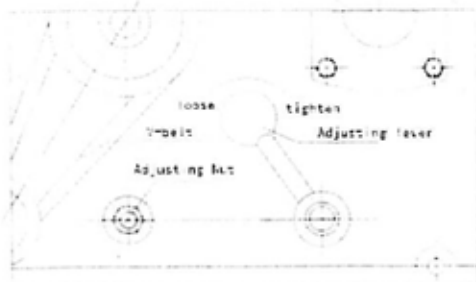

Figure 7-Loosen nut and Engage Lever

3. Push in on the belt approximately $\frac{1}{4}$ to $\frac{1}{2}$ (0.64 to 12.7mm) and hold.
4. Retighten the adjusting nut.

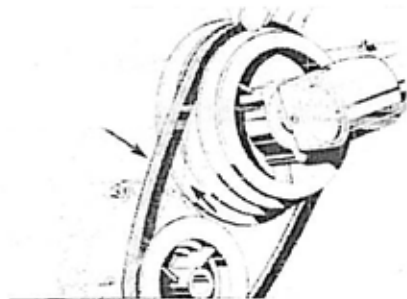

Figure 8-Press the belt in and tighten the adjusting nut

Basic Operation of Handwheel

Clockwise rotation of the spindle feed handwheel retracts the spindle in towards the lathe.

Clockwise rotation of the cross feed handwheel moves the cutting tool in towards the lathe.

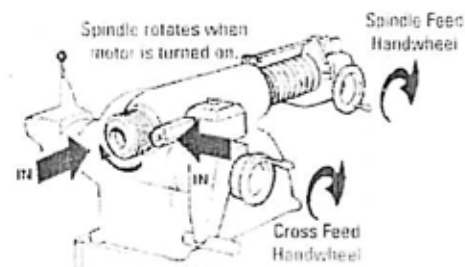

Figure 9-Clockwise rotation of handwheel

Counterclockwise rotation of the spindle feed handwheel extends the spindle out away from the lathe.

Counterclockwise rotation of the cross feed handwheel moves the cutting tool out away from the lathe.

INSTALLATION

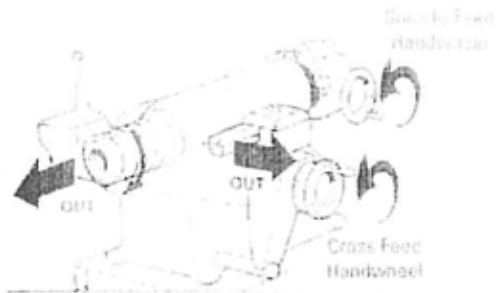

Figure 10-Counterclockwise rotation of handwheels

Reconditioning Brake drums

Preparation

1. Measure the diameter of the brake drum with a brake drum micrometer.

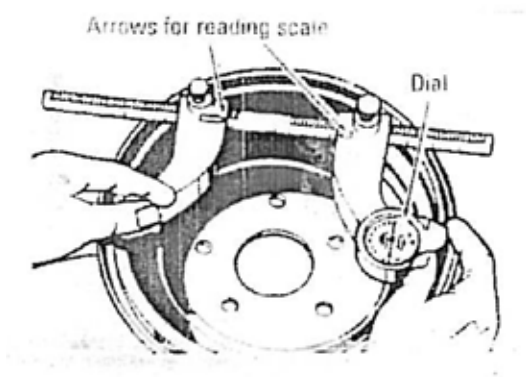

Figure 11-Measure drum diameter

2. Determine if the drum will be within maximum rebores limits after reconditioning.

Note: most often, the discard diameter is cast into the brake drum, not the maximum machining diameter.

3. Inspect brake drum. do not attempt to machine a drum that is damaged or in poor condition.

Mounting Drums

1. loosen the boring bar clamp nut and push the boring bar all the way into the clamp.
2. Mount the drum on the arbor using the proper adapters, cones, and spacers. Use examples in Figure 15 for guidance.
3. Wrap the drum silencer band snugly around the drum. Be sure It covers up to the right-hand edge.

INSTALLATION

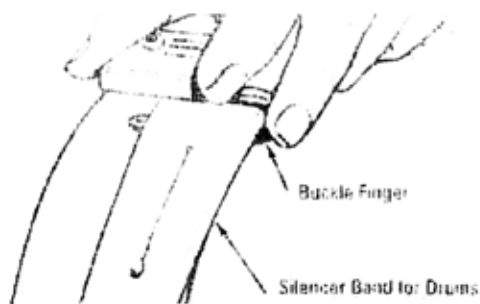

Figure 12-Attach silencer band

Important: The spindle feed handwheel will not operate unless the spindle feed engagement lever is in the OFF position. Feed should only be adjusted when the spindle is turning.

4. Position the cross slide and spindle by turning the cross feed handwheel to maximum clockwise position. Then back off the cross feed handwheel 2 complete turns.
5. Position the boring bar by loosening the boring bar clamp nut and sliding the boring bar inward toward the drum until the tool bit is close to the drum.

The boring bar position is changed whenever a drum of different diameter is machined.

The entire boring bar clamp may also be swiveled to achieve the best cutting position.

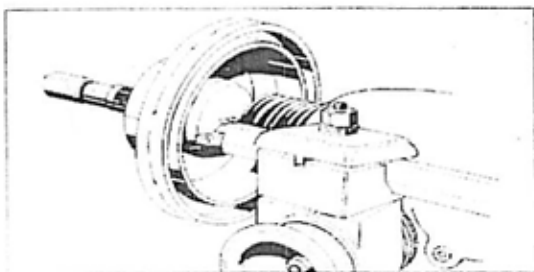

Figure 13- Positioning the boring bar

6. Turn the drum by hand to make sure that everything is clear.
7. Turn the lathe ON.
8. Advance the tool bit manually until it just contacts the drum surface momentarily and makes a scratch cut.

INSTALLATION

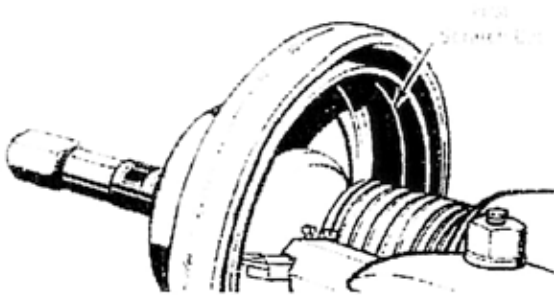

Figure 14-First scratch cut

9. Back the tool bit off and turn the lathe OFF.
10. Loosen the arbor nut, rotate the drum 112 turn (180°), and retighten the nut.
11. Turn the lathe ON.

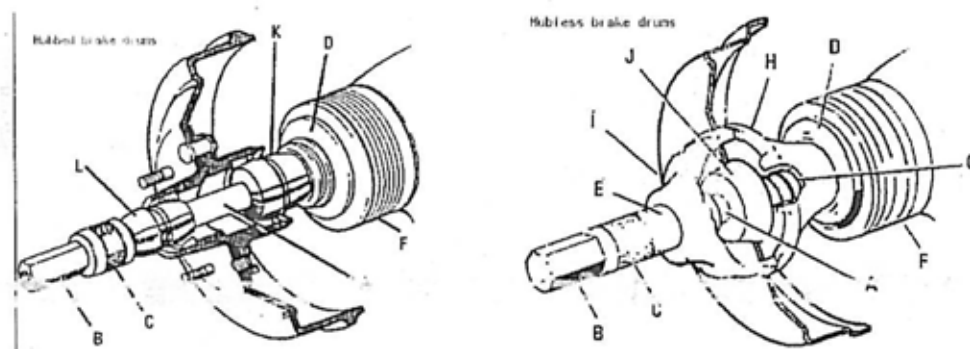

Figure 15-Typical drum mounting configurations

A. 1" Arbor B. Arbor Nut C. Self-Aligning Spacer D. Lathe Spindle Nose E. Spacer
 F. Protective Boot G. Spring H. Inside Floating Adapter I. Outside Floating Adapter J. Centering Cone
 K. Large Double Taper Adapter L. Small Double Taper Adapter
Hubbed Brake Drums: Tapered cone adapters fit in the bearing seats, making contact near the middle of the bearing race whenever possible rather than near an edge. Various adapters and spacers may be used to fill out the shaft of the arbor.
Hubless Brake Drums: Slip the hubless adapter onto the arbor followed by inside Floating Adapter, a spring, the cone, the drum, and another hubless adapter. Fill out the shaft with spacers as needed.
Note: The self-aligning spacer should always be used next to the arbor nut when tightening. To avoid overtightening, wrench tighten the arbor nut counterclockwise until the drum and adapters begin to turn on the arbor, then continue to advance the wrench of a turn. Do not overtighten the arbor nut.

INSTALLATION

12. Turn the spindle feed handwheel 1/2 turn in either direction and make a second scratch cut. No change the drum diameter

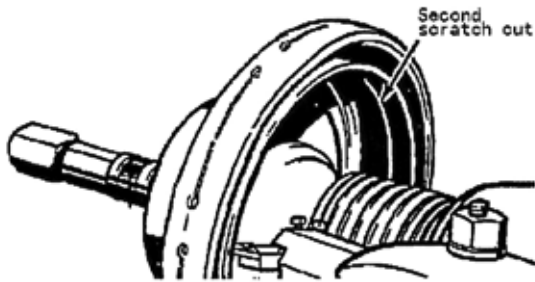

Figure 16-Second scratch cut

13. Turn the lathe OFF.

14. Examine the scratch cuts.

If the first and second cuts are opposite one another (180° apart), fix wrong, remove the drum from the arbor, check the mounting adapters and arbor for nicks, burrs, or chips, remount the drum, and repeat scratch cut process.

If the scratches are side by side, fix right, proceed to step 15.

15 Turn the spindle feed hand-wheel until the deepest worn groove of the drum lines up with the point of the tool bit.

16. Advance the tool bit into the bottom of the groove by rotating the cross feed hand-wheel counter clock wise.

Note: These operations may be done with the lathe running.

In cross feed dial, one case means 0.002" (0.05mm).

17. Determine the depth-of-cut:

- Roughing cuts should be no deeper than 0.020"(0.5 mm).

- Finish cuts should be no shallower than 0.004"(0.1 mm).

18. With the lathe running, set the depth-of-cut dial to the depth desired and lock the cross feed by tightening the lock knob.

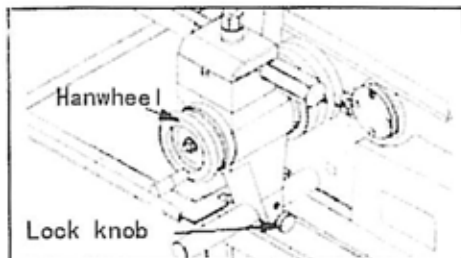

Figure 17-Lock cross feed

INSTALLATION

19. Through slide Control rod Lock on SPindle Travel Control rod a point near equation drum deep, stop auto feed. Spindle Feed CLutch Lever breaks away, spindle feed stop.

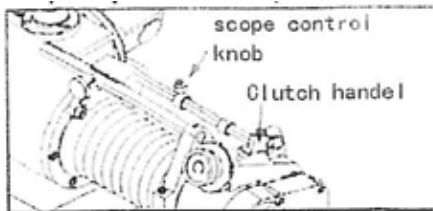

Figure 18-Set limited travel

20. Examine spindle lock, engage spindle feed clutch lever (clutch lever moves lift until spindle feed handwheel rotates), then machining drum until satisfaction. Spindle feed speed is adjusting through spindle feed dial. Fast is roughing cuts, slow is finish cuts. Remember: Spindle feed speed must be adjusted with the lathe running other.vise be mangled.

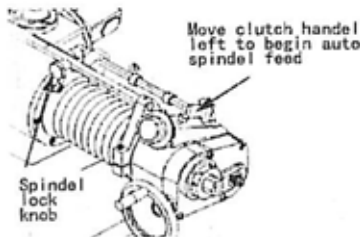

Figure 19-Spindle auto feed

Reconditioning Disc Brake Rotors Preparation

1. Inspect the rotor carefully for scoring, rust ridges (at the inner and outer circumference of the rotor), and hard spots. Any excessive wear or deformity should be noted and if not within acceptable limits, the rotor should be replaced.

2. Use a micrometer to check the thickness of the rotor at no less than 3 points around the circumference about 1" (2.54mm) in from the outer diameter.

If the rotor thickness varies between readings, it should be reconditioned. However, if the thickness is less than the minimum established by the manufacturer, or if will be less after reconditioning, the rotor should be replaced.

Note: Most often the discard thickness dimension is cast or stamped into the rotor, not the minimum machine to thickness.

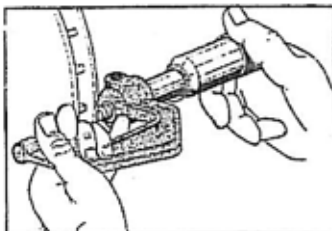

Figure 20-Measure rotor thickness

INSTALLATION

Twin Cutters

Twin cutters can cut two surfaces of disc.

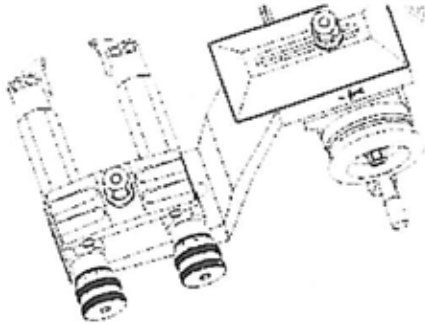

Figure 21-Fix twin cutters

Rotor Mounting

Review the descriptions of mounting a brake drum on page 6. The same directions apply when mounting a brake rotor. Spacers are used to fill out the arbor shaft so that the arbor nut can be tightened. The setups illustrated in Figure 22 are typical of the many mounting configurations necessary to meet the requirements of brake rotor reconditioning. The adapters, cones and spacers supplied with the lathe will allow reconditioning of the majority of the rotors found on the current production vehicles.

Note: Adapters may also be used as spacers to fill out the arbor shaft if care is taken to prevent damage to their machined surfaces.

The self-aligning spacer prevents diagonal thrust on the adapters. The self-aligning spacer should always be used adjacent to the arbor nut.

- A- 1" Arbor
- B -ArborNut
- C - Self-Aligning Spacer
- D - Spacer
- E - Spring
- F - Small Hubless Adapter
- G - Large Hubless Adapter
- H - Centering Cone
- I - Small Double Taper Adapter
- J - Large Double Taper Adapter
- K - Adapter, Used as Spacer

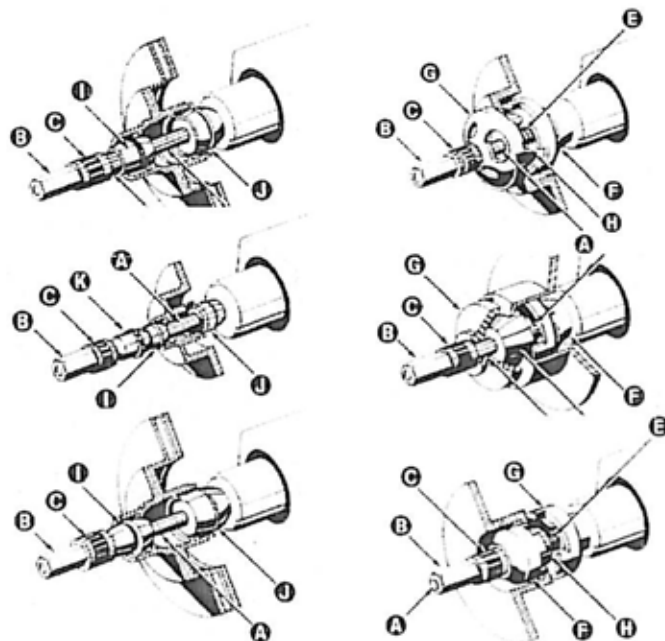

Figure 22-Fix disc (continued)

INSTALLATION

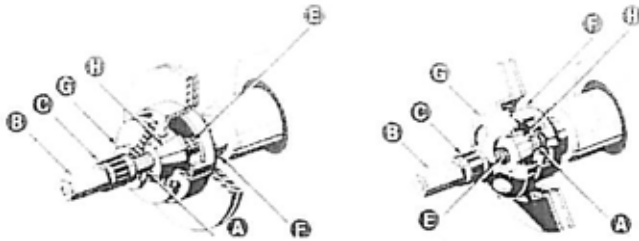

Figure 22-Fix disc (continued)

Set Up and Reconditioning Rotors

1. Install a silencer band on the mounted rotor. Stretch the band around the rotor and hook the metal loop over a lead weight.

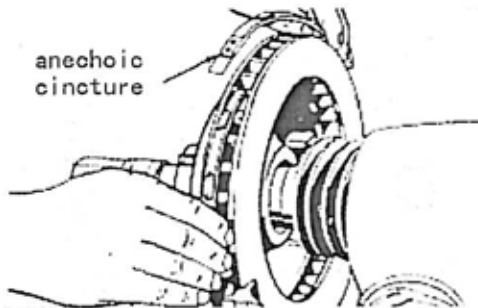

Figure 23-Attch silencer band

2. Center the twin cutter to the rotor. The twin cutter should be approximately parallel to the lathe spindle.

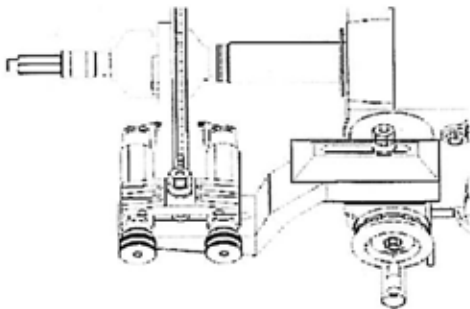

Figure 24-Center the twin cutter

3. Install the safety shield. Review the cautions and dangers section and the general safety information at the beginning of this manual.



Always wear safety glasses or a face shield. Cutting or grinding on an exposed surface such as a rotor will produce flying chips and debris.

4. Adjust the drive belt to match the rotor size. Use the outer pulley groove for passenger car and most light duty truck rotors. Choose one of the inner pulley (Continued next page)

INSTALLATION

grooves when machining medium duty and larger truck rotors and some solid rotors.

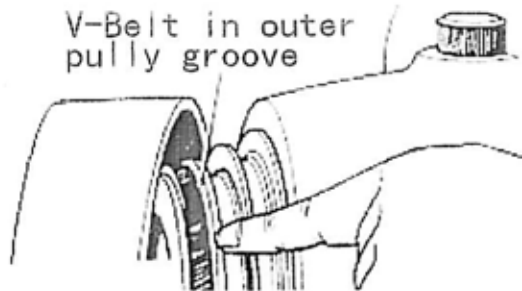

Figure 25-Adjust drive belt location

5. Make sure that the tool bits clear the rotor surfaces and the silencer band. Give the rotor a full turn by hand and watch for clearance all the way around.
6. Turn the lathe ON.
7. Turn each tool bit control (the outer knurled knobs) clockwise until the tool bits just contact the rotor surfaces.
8. When the tool bits make contact, rotate each of the inner depth-of-cut collars to zero and back the tool bits away from the rotor.

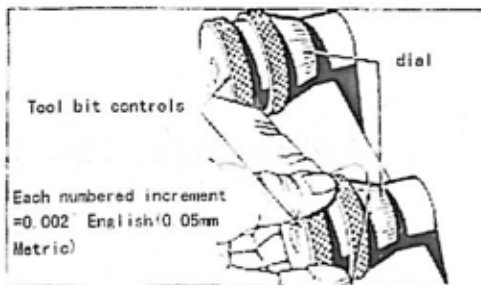

Figure 26-Tool bit controls

9. Turn the cress feed hand wheel until the tool bits are at mid-point of the rotor face.
10. Turn the left hand tool bit control until the tool bit contacts the rotor surface and makes a scratch cut. After the cut is made, back the tool bits off and turn the lathe off. The scratch will usually appear as an incomplete circle. This is caused by run out or wobble duo to rotor condition, or by the way the rotor is mounted on the arbor.

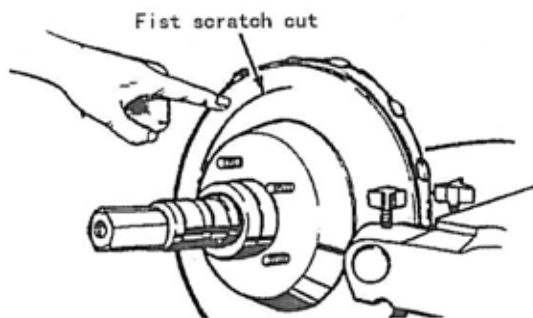

Figure 27-First scratch cut

INSTALLATION

11. Check rotor mounting by loosening the arbor nut and turning the rotor 180° by hand on the arbor. Make sure the inside adapter does not rotate along with the rotor. Then retighten the arbor nut, turn the cross feed handwheel back 1/2 turn, turn the lathe ON, and repeat step 10 to make a second scratch cut.

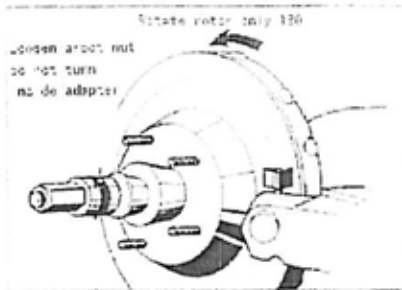

Figure 28-Rotate rotor 180°

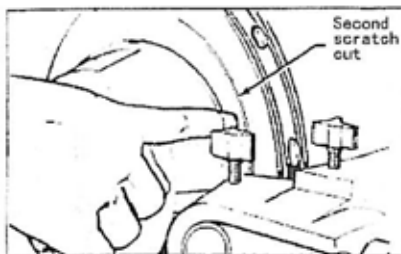

Figure 29-Second scratch cut

12. If the scratch cuts are side; the run out of wobble is caused by rotor condition. A centesimal meter may be used to compare rotor runout with manufacture's specifications.

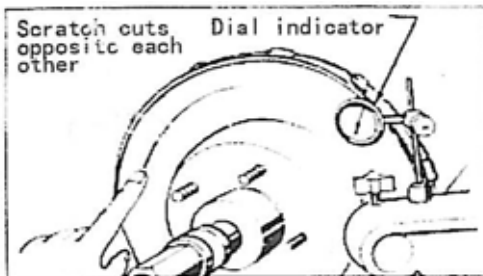

Figure 30-Using a centesimal meter

13. If the scratch cuts are opposite of one another (180°), the rotor may not be properly mounted on the arbor. Remove the rotor and examine the arbor and all adapters for nicks, burrs, chips, dirt, or rust. Inspect the rotor hub for loose or damaged bearing cups. Clean, repair, remount, or replace as necessary.

14. Recheck the setting of the depth-of-cut collars which were set to zero earlier by moving the tool bits inward until they just contact the surfaces of the rotor. The collars should be at zero. Reset the collars if necessary.

15. Turn the cross feed handwheel clockwise until the tool bits are near the rotor hub.

16. Turn the lathe ON.

17. Turn both tool bit controls to the desired depth-of-cut and lock them in position by tightening the red lock knobs above the tool bits.

INSTALLATION

Note: Either rough or finish cuts may be taken to resurface a rotor. Generally, finish cuts should be 0.004" (0.10 mm) to 0.006" (0.15 mm) per side. Very shallow cuts of less than 0.004" (0.10 mm) per side tend to reduce tool bit life because the heat generated during reconditioning isn't transferred to the rotor efficiently. Rough cuts may be taken from 0.006" to 0.010" per side.

18. Engage the automatic cross feed by moving the lever to the desired speed. When the drum is cut. Move lever to middle location, turn off the lathe, exam surface, then recutting disqualification.

Note: For roughing cuts, move the cross feed lever to the FAST position.

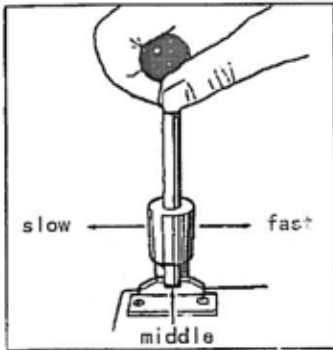

Figure 31-Engage automatic cross feed

Typical Adapter Usage for Rotors

Before you begin

It is important in any machining operation that all adapters and mounting hardware, as well as disc to be machined, are clean and free of nicks.

IMPORTANT: The flange plate must contact the flat portion of the disc, but must not contact the rotor anywhere around the outside radius. Arbor nut does not overtighten.

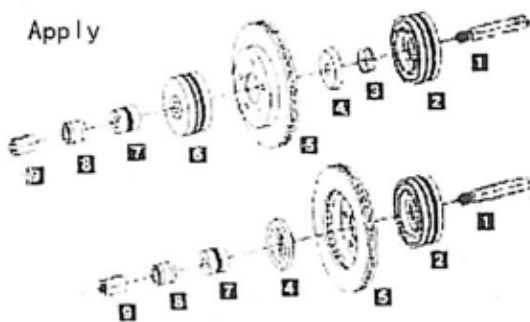

1-1" Arbor 2-Flange Plate 3-Spring 4-Centering Cone 5-Disc 6- Flange Plate
7-Spacer 8-Self-Aligning Spacer 9-Arbor Nut

INSTALLATION

CROSS FEED EXTENSION INSTALLATION INSTRUCTIONS

The cross feed extension is used to increase the capacity of the twin cutter to machine large diameter brake discs on the standard brake lathe.

The placement of the twin cutter on the cross feed extension is determined by the diameter of the disc to be machined.

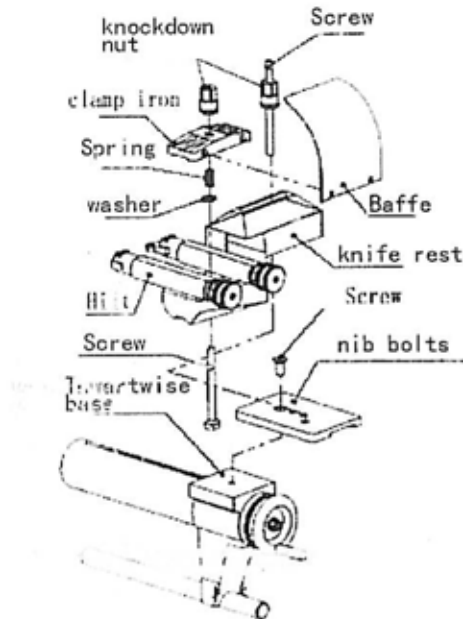

Referring to the illustration, remove the cross feed locking stud and clean all surfaces of chips. Mount the cross feed extension plate directly on the cross feed seat.

Insert the locking stud (with nut and washer assembly) through the cross shelves joint cross feed extension. Hand tighten the stud using the knurled head. Turn the nut and washer assembly down with a wrench to lock the cross shelves in place.

Maintenance and Service Oiling

Oiling

The lathe is shipped from the factory with the correct amount and type of oil. Check oil level frequently and refill as necessary with MOBIL EP-80-90 lubricating oil.

INSTALLATION

Cleaning

Keep the lathe as clean as possible for trouble-free operation, as well as safety and longer lathe life. Use a brush to sweep metal chips and dust off the lathe.

Do not use compressed air to blow the lathe clean.

Chips and dust may be driven between machined parts and into bearings, causing undue wear.

Care of Arbors and Adapters

Although the adapters, arbors, and spindle are made of top grade steel and are turned, hardened, and precision ground to close tolerances, great care should be taken in their use, handling, and storage. Even the smallest nick, scratch, or loose chip can cause incorrect rotor or drum alignment, resulting in inaccurate reconditioning.

Remove all adapters from the arbor after reconditioning a drum or rotor and wipe them clean — especially the Inboard adapter. When a finished drum or rotor is removed from the arbor, the inboard adapter may move slightly away from the face of the arbor and allow metal chips to fall into the opening, causing a poor mounting for the next drum or rotor

Regularly inspect the faces and seating tapers of the adapters for nicks and scratches, correct any flaw with a fine stone. If the damage cannot be corrected, replace the adapter. Handle the adapters and arbors with care and store them on individual hooks. Do not throw them into a box. The adapters are designed for mounting drums and rotors only. Do not misuse the adapters.

IMPORTANT INFORMATION REGARDING OPERATION SAFETY AND EYE AND FACE PROTECTION

Protective eye and face equipment is required to be used where there is a reasonable probability of injury that can be prevented by the use of such equipment.

In addition to a safety shield, protective goggles, safety spectacles, or a face shield must be provided by the purchaser/user and worn by the operator of the equipment. Care should be taken to see that all eye safety precautions are observed by the operator.

Pro-Series Equipment
P.O. Box 734
Franklin, IN

Pro-Series Equipment
P.O. Box 734
Franklin, Indiana
ATTN: Warranty Dept.

Place
Stamp
Here